

AN INNOVATIVE E-NOSE APPROACH FOR FOOD QUALITY ASSESSMENT: A MST SOLUTION EXPLOITING GAS-CHROMATOGRAPHIC SELECTIVITY

I. Elmi*, S. Zampolli, G.C. Cardinali

CNR – IMM Bologna, Via P.Gobetti,101, 40129 Bologna (Italy)

L. Francioso, M. Epifani, P. Siciliano

CNR – IMM Lecce, Via Arnesano, c/o Campus Universitario Ecotekne, 73100 Lecce (Italy)

Abstract

State of the art electronic noses based on arrays of solid state gas sensors typically allow the qualitative analysis of an unknown gas mixture, sampled from the food to be classified. In several cases the presence of unexpected interfering gases may negatively affect the results of the analysis. Furthermore, for a reliable food quality assessment a quantitative evaluation of the relevant target gases is mandatory. For this reason, nowadays complex gas chromatographic systems are used, which generally are bulky and expensive laboratory instruments requiring complex sampling procedures.

The use of simplified gas chromatographic separation techniques together with the e-nose approach will allow developing an innovative system, which will reliably perform quantitative analyses. In particular, through the use of solid state gas sensor arrays, the developed system will not need to rely on external carrier gas cylinders, resulting in a portable device optimized for the specific agro-food application.

After a brief introduction of the principles of gas-chromatography, we will show how the temporal selectivity provided by GC columns combined with the chemical selectivity of sensor arrays is expected to allow quantitative analyses of some typical volatile tracers of fish freshness.

The architecture of the gas-chromatographic e-nose and the micromachined components used for MST integration will be presented. Finally, preliminary results of DMA and TMA separation for fish freshness evaluation obtained with prototypal packed GC columns will be discussed.

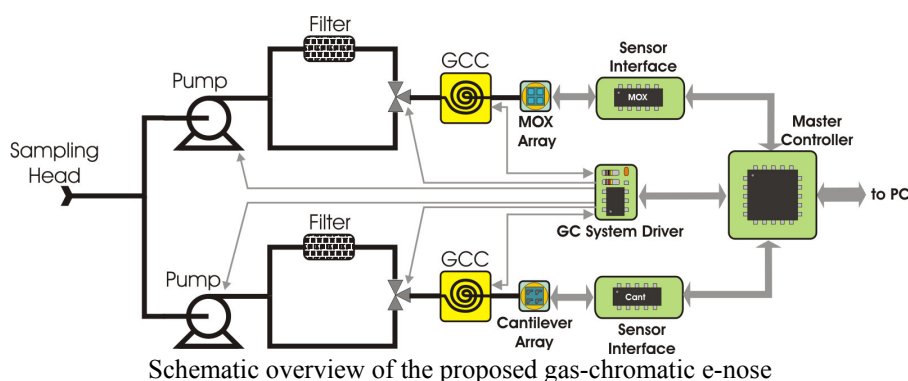

* **CORRESPONDING AUTHOR:** E-mail: elmi@bo.imm.cnr.it, Ph: +39 - 051 639 9109, Fax: 639 9216